

Shield IR-V4

1) Introduction

The IR-V4 module is a contactless switch used to control LED luminaires. For more information see the IR-V4 module datasheet. In this document we describe how to use the module with a shield (Figure 1) and how to mount it on a mirror with a picture in front of the switch - the logo.

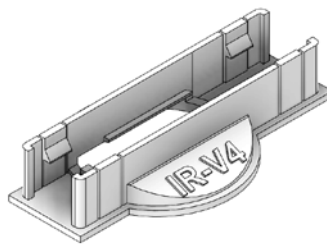
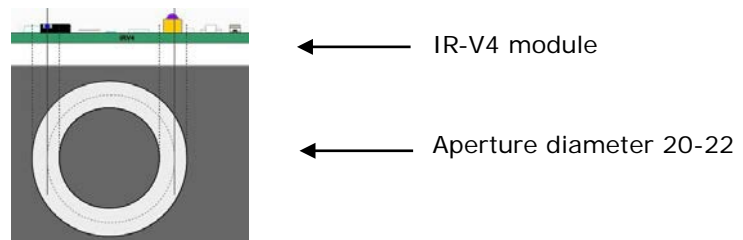

Fig. 1: Shield IR-V4

The following figure (2) shows the principle of the IR-V4 module operation on a mirror with a sandblasted ring, namely logo. The logo is placed above the IR-V4 module and the mirror is not touching the module.

The position of the sensor aligns with the logo for optimal IR light radiation. This enables the IR-V4 module seamless sensitivity performance, including illumination of the logo. The module illuminates the sandblasted image on the mirror/glass from the bottom up.

The sandblasted glass should be between 3 - 5 mm thick. Essentially, the thicker the sandblasted glass, the lower the sensitivity of the IR-V4 module. For more information about the sensitivity, see the IR-V4 module datasheet.



Outer edge	20-22 mm
Centre	18,5 mm
Inner edge	17-15 mm
Ring thickness min. 3 mm	

Fig. 2: Cross-section of the IR-V4 and positioning on the mirror with the logo

1.1) Different logos

The shape of the switch is made according to the user's preference, but it follows the design or dimensions of the aperture, with two circles (minimum diameter of 3 mm and distance from the center of the aperture is 18,5 mm), see Figure 3, while the Figure 4 shows examples of the logo.

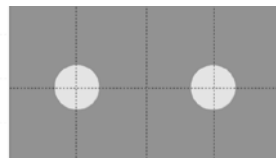

Fig. 3: Minimum Aperture Concept

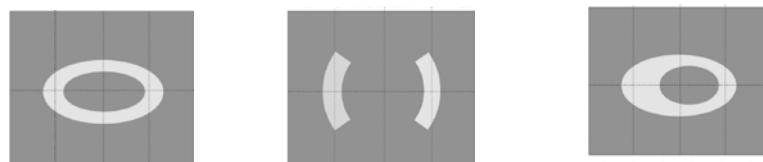

Fig. 4: Examples of logos

It should be noted that with the IR-V4 shield the logo aperture design should follow the circular shape for optimal optical and color light radiation.

1.2) Different logo colors

In the following figure (5) we can see the illuminated logo of the switch (ring) in different colors (e.g. green, blue, violet, white)¹.

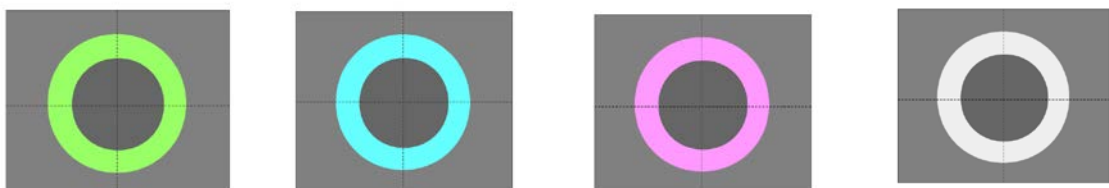

Fig. 5: Different logo colors

¹ Upon request it is possible to set a particular color.

2) Installation of IR-V4 shield and module

The figure (6) shows the shield and the IR-V4 module. On the left side is the top view, while on the right side is the bottom view.

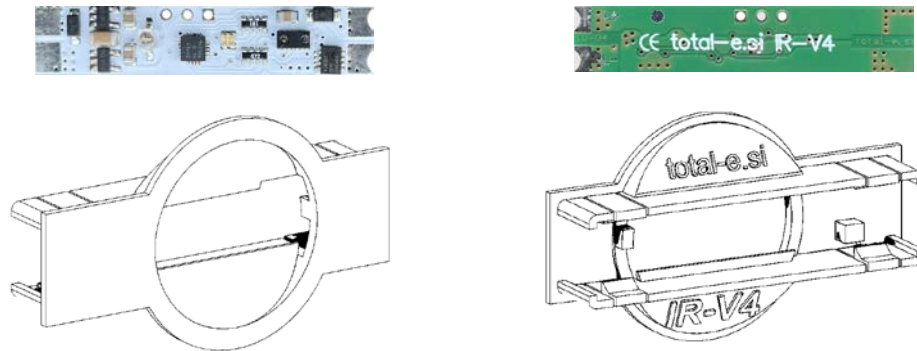
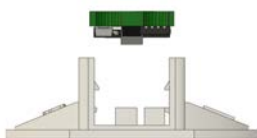

Fig. 6: Shield and module IR-V4

Before we can insert the IR-V4 into the shield, the connecting wires should be soldered first. In Figure (7) we can see and read more about the *three steps* how to insert the IR-V4 module into the shield.



1. First, anchor the IRV4 module in the shield frame so that the IRV4 lettering on the module and the shield match, see Figure 6, right.



2. When the IR-V4 module is anchored in the shield's frame, then we insert the module into the shield by pressing/pushing it into the shield with relative force, so that the side teeth grip the module, see Figure 7, Step 3.



3. IR-V4 module is inserted in the shield.

Fig. 7. Inserting the IR-V4 module into the shield

3) Positioning shielded IR-V4

The shielded IR-V4 module is centered using the centering lines drawn during the logo sandblasting process.²

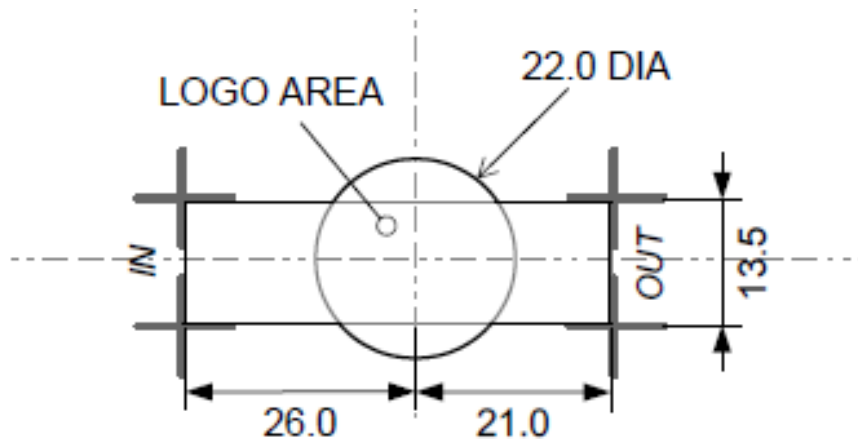

Fig. 8 The example of sandblasting template and shield positioning (in mm).

The corners of the sandblasted logo and its markers (see Figure 8) are accurately aligned with the assembled IR-V4 module and its shield.

To ensure the tightest possible fixing, use thin double-stick tape (e.g. 3M). For even better protection of the IR-V4 module, e.g. against moisture or condensation the IR-V4 module and its shield can also be covered with the so-called DUCK TAPE (3M).

² During the sandblasting process, pay attention to the size of the actual template. We suggest using a larger frame, such as the one shown in the Fig. 8. How large the frame is is-left to the user, but it should be large enough to protect the logo during the sandblasting process.